

PRM[®] MOTOR

Service and Repair Manual

BLN-52179
June 2018

TABLE OF CONTENTS

Section	Page
Foreword	1
Description and Operation	2
Introduction	2
General Description	2
External Features	3
Technical Specifications	4
Product Identification	4
Safety	5
Personal Safety	5
Tool Safety	5
Work Area Safety	5
Servicing Safety	5
Troubleshooting	6
Service and Maintenance	7
External Maintenance	7
Service and Maintenance Procedures	7
Fluids	7
Fluid Volume and Level	7
Fluid Change	7
Repair	8
How To Use This Manual	8
General Instructions	8
Required Tools	8
Torque Specifications	8
PRM Motor Removal	8
Tools	8
Disassembly	9
Assembly	17
Parts List	24-25
Glossary of Terms	26

FOREWORD

Headquartered in Sullivan, Illinois, Hydro-Gear® is a world leader in the design, manufacture, and service of quality hydrostatic transaxles for the lawn and garden industry. The mission of our company is to be recognized by our customers and the industry as a world-class supplier and the quality leader in everything we do.

This Service and Repair Manual is designed to provide information useful in servicing and troubleshooting the Hydro-Gear PRM®.

Also included is a glossary of terms that are frequently used throughout the industry and in Hydro-Gear service publications. Understanding terminology is very important!

It is necessary, and a good shop practice, that your service area be equipped with the proper tools and the mechanics be supplied the latest information available. All repair procedures illustrated in this guide are suggested, but preferred methods of repair.

Repair procedures require that the PRM unit be removed from the vehicle.

This is not a certification, test or study guide for a certification test. If a technician is interested in certification, they should contact an agent representing the OPEESA (Outdoor Power Equipment and Engine Service Association) at (860) 767-1770 or their Hydro-Gear Central Service Distributor. Many distributors will be hosting certification testing. These study guides will cover most of the products and manufacturers in our industry.

For more information about Hydro-Gear or our products, please contact your Central Service Distributor, or call our Customer Service Department at (217) 728-2581.

SECTION 1. DESCRIPTION AND OPERATION

INTRODUCTION

The purpose of this manual is to provide useful information for servicing the Hydro-Gear® PRM® Motor. This manual includes a PRM general description, technical specifications, product identification, safety, troubleshooting, maintenance, and repair procedures.

The PRM Motor normally will not require servicing during the life of the vehicle in which it is installed. Should other servicing be required, the PRM Motor will need to be thoroughly cleaned before beginning most procedures.

Please refer to the instructions titled “How to Use This Manual” in the Repair Section for an explanation of the layout of the disassembly and reassembly portions of this manual.

GENERAL DESCRIPTION

The PRM is a fixed displacement axial piston motor. The motor is designed to convert hydraulic power into rotational power at the axle shaft. It operates at an infinitely variable speed range between zero and maximum axle speed determined by motor displacement and maximum pump flow in both forward and reverse modes of operation.

The PRM motor is available in four different displacements that range from 14 to 20 cu. in. (229 to 327 cc) per revolution. The cylinder block pistons in the PRM Motor are set at a fixed displacement by a fixed swash angle that is integral to the motor housing. Therefore, the motor is always at maximum displacement. As pressurized fluid from the pump pushes against the cylinder block pistons, they are forced to rotate with the thrust bearing. As the pistons rotate with the thrust bearing, they create torque and rotary motion that is transmitted to the axle shaft. Torque continues to develop as long as the piston is being pushed out of the cylinder block. When the piston reaches the end of its movement out of the cylinder block, it gets pushed back into the cylinder and fluid inside the piston is discharged through the low pressure port of the motor. Pistons develop torque only through half of the cylinder block rotation cycle. Therefore, multiple pistons are used to provide a constant and continuous torque to the motor shaft. Reversing the direction of the incoming pressurized fluid into the motor reverses the direction of the motor output rotation.

The PRM motor utilizes a friction type brake controlled by a cam attached to an actuating arm.

EXTERNAL FEATURES PRM MOTOR

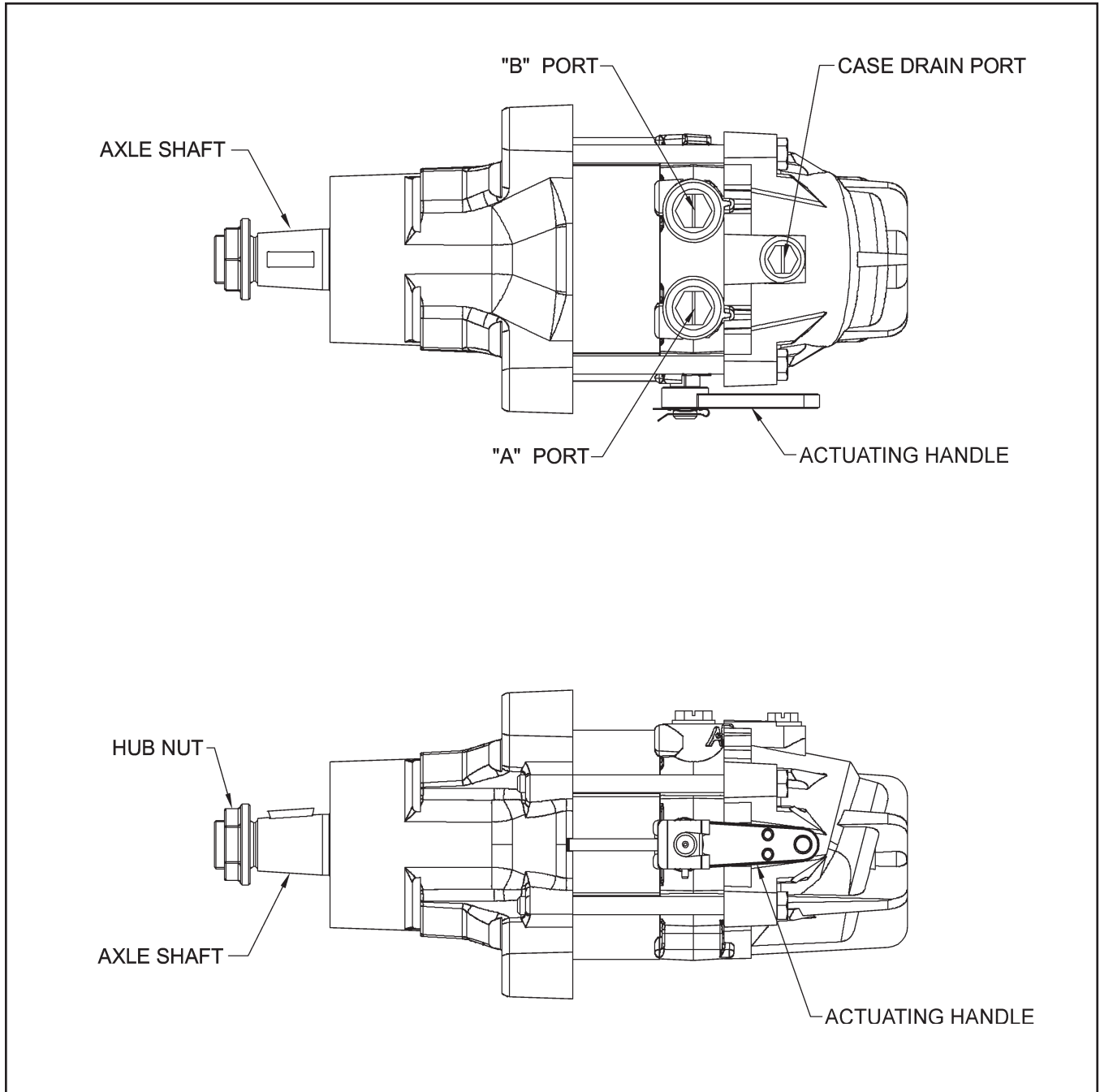

Figure 1. PRM® External Features

TECHNICAL SPECIFICATIONS

Technical specifications for the PRM® are given in Table 1.

	PRM
Geometric Displacements in ³ /rev [cc/rev]	14 16 18 20 [229] [262] [294] [327]
Maximum Speed rpm [min-1]	240 [240]
Maximum Torque (@ 3000 psi [206 bar]) lb-ft [daNm]	600 [81]
Shaft (diameter)	1.25" SAE J501 taper
Hub Options	4 bolt with 1/2"-20 studs 5 bolt with 1/2"-20 studs
Weight (filled with oil) lb [kg]	42.4 [19.2]

Table 1. Technical Specifications

PRODUCT IDENTIFICATION

The model and configuration of the PRM can be determined from the label shown in Figure 2.

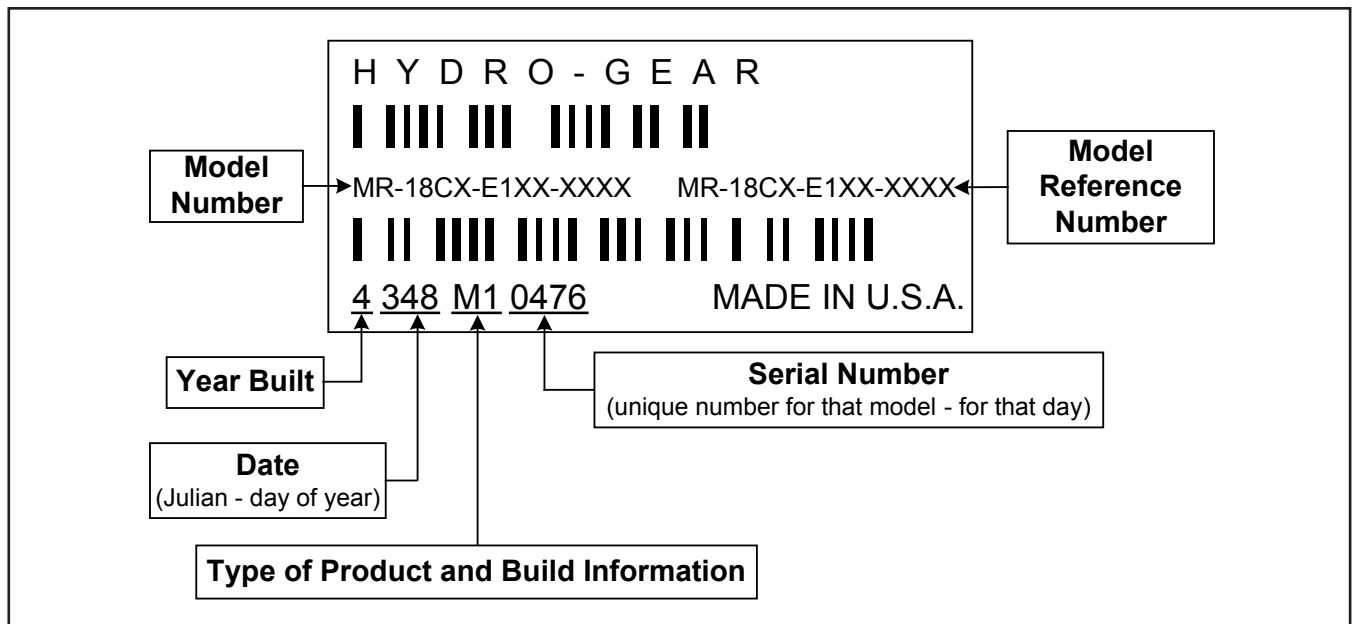

Figure 2. PRM Configuration Label

SECTION 2. SAFETY



This symbol points out important safety instructions which, if not followed, could endanger the personal safety and/or property of yourself and others. Read and follow all instructions in this manual before attempting maintenance on your PRM® motor. When you see this symbol - **HEED ITS WARNING.**



WARNING

POTENTIAL FOR SERIOUS INJURY

Inattention to proper safety, operation, or maintenance procedures could result in personal injury, or damage to the equipment. Before servicing or repairing the PRM, fully read and understand the safety precautions described in this section.

PERSONAL SAFETY

Certain safety precautions must be observed while servicing or repairing the PRM. This section addresses some of these precautions but must not be considered an all-inclusive source on safety information. This section is to be used in conjunction with all other safety material which may apply, such as:

- 1) Other manuals pertaining to this machine
- 2) Local and shop safety rules and codes
- 3) Governmental safety laws and regulations

Be sure that you know and understand the equipment and the hazards associated with it. Do not place speed above safety.

Notify your supervisor whenever you feel there is any hazard involving the equipment or the performance of your job.

Never allow untrained or unauthorized personnel to service or repair the equipment.

Wear appropriate clothing. Loose or hanging clothing or jewelry can be hazardous. Use the appropriate safety equipment, such as eye and hearing protection, and safety-toe and slip-proof shoes.

Never use compressed air to clean debris from yourself or your clothing.

TOOL SAFETY

Use the proper tools and equipment for the task.

Inspect each tool before use and replace any tool that may be damaged or defective.

WORK AREA SAFETY

Keep the work area neat and orderly. Be sure it is well lit, that extra tools are put away, trash and refuse are in the proper containers, and dirt or debris have been removed from the working areas of the machine.

The floor should be clean and dry, and all extension cords or similar trip hazards should be removed.

SERVICING SAFETY

Certain procedures may require the vehicle to be disabled in order to prevent possible injury to the servicing technician and/or bystanders.

The loss of hydrostatic drive line power may result in the loss of hydrostatic braking capability. Proper brake maintenance is very important should this condition develop.

Some cleaning solvents are flammable. Use only approved cleaning materials: do not use explosive or flammable liquids to clean the equipment.

To avoid possible fire do not use cleaning solvents in an area where a source of ignition may be present

“Discard used cleaning material in the appropriate containers according to local, state, and federal regulations.”

SECTION 3. TROUBLESHOOTING



WARNING

Do not attempt any servicing or adjustments with the engine running. Use extreme caution while inspecting the drive belt assembly, and all vehicle linkage!

Follow all safety procedures outlined in the vehicle owner's manual!

In many cases problems with the PRM® motor are not related to a defective motor, but may be pump related problems which can be caused by slipping drive belts, partially engaged bypass valves, and loose or damaged control linkages. Be sure to perform all operational checks and adjustments outlined in Section 4 before assuming the unit is malfunctioning. Table 2 below provides a troubleshooting check list to help determine the cause of operational problems.

Possible Cause	Corrective Action	Refer To:
UNIT OPERATES IN ONE DIRECTION ONLY		
Control linkage bent or out of adjustment Drive belt slipping or pulley damaged	Repair or replace linkage Repair or replace drive belt or pulley	Vehicle Owner's Manual Vehicle Owner's Manual
UNIT IS NOISY		
Oil level low or contaminated oil Excessive loading Loose parts Air trapped in hydraulic system Internal gear failure	Fill to proper level or change oil Reduce vehicle loading Repair or replace loose parts Purge hydraulic system Complete teardown & reassembly	Fluid Maintenance, Page 7 Vehicle Specifications Appropriate Repair Procedure Pump Manual PRM Service & Repair Manual
UNIT HAS NO/ LOW POWER		
Engine RPM low Control linkage bent or out of adjustment Drive belt slipping or pulley damaged Oil level low or contaminated oil Excessive loading Air trapped in hydraulic system	Adjust to correct setting Repair or replace linkage Repair or replace drive belt or pulley Fill to proper level or change oil Reduce vehicle loading	Vehicle Specifications Owner's Manual Owner's Manual Fluid Maintenance, Page 7 Vehicle Specifications Pump Manual
UNIT OPERATING HOT		
Debris buildup around motor Oil level low or contaminated oil Excessive loading Air trapped in hydraulic system	Clean off debris Fill to proper level or change oil Reduce vehicle loading Purge hydraulic system	Fluid Maintenance, Page 7 Vehicle Specifications Pump Manual
MOTOR LEAKS OIL		
Damaged seals, housing, or gaskets	Replace damaged component	Appropriate Repair Procedure

Table 2. Troubleshooting Checklist

SECTION 4. SERVICE AND MAINTENANCE

NOTE: Any servicing dealer attempting a warranty repair must have prior approval before conducting maintenance of a Hydro-Gear® product unless the servicing dealer is a current Authorized Hydro-Gear Service Center.

EXTERNAL MAINTENANCE

Regular external maintenance of the PRM® should include the following:

1. **Check the vehicle operator's manual for the recommended load ratings. Insure the current application does not exceed load rating.**
2. Check fluid level in drive system reservoir in accordance with vehicle manufacturer's recommendations.
3. Inspect all external plumbing for possible leaks or loose fittings.
4. Insure the reservoir is free of contaminants and is properly vented.
5. Remove any obstructions (grass clippings, leaves or dirt).
6. Inspect the vehicle control linkage to the brake arm on the PRM motor.

SERVICE AND MAINTENANCE PROCEDURES

NOTE: Damage to PRM's may result from external or internal contamination: Heat from excess debris or lack of lubrication and over-pressurization of the product. Follow guidelines established in this manual and the vehicle manufacturer's recommendations.

Note: "Any and all Hydro-Gear components removed and replaced during service are recyclable."

Cleanliness is a key factor in the successful repair of PRM's. Thoroughly clean all exposed surfaces prior to any type of maintenance. Cleaning of all parts by using a solvent wash and air drying is usually adequate. As with any precision equipment, all parts must be kept free of foreign material and chemicals. Protect all exposed sealing areas and open cavities from damage and foreign material.

Upon removal, all seals, O-rings, and gaskets should be replaced. During installation, lightly lubricate all seals, O-rings, gaskets with clean petroleum jelly prior to assembly. Also, protect the inner diameter of seals by covering the shaft's machined features with plastic wrap or equivalent. Remove plastic wrap after seal is installed.

FLUIDS

The fluids used in Hydro-Gear products have been carefully selected, and only equivalent, or better products should be substituted.

Typically, an engine oil with a minimum rating of 9.0 cSt (55 SUS) at 230° F (110° C) maximum operating temperature and an API classification of SJ/ CD is allowed. Refer to the vehicle manufacturer for recommended oil.

"All fluids should be handled and disposed of according to local, state, and federal regulations."

FLUID VOLUME AND LEVEL

Certain situations may require additional fluid to be added or even replaced. Refer to the vehicle manufacturer's recommendations for the proper fill location and level.

FLUID CHANGE

In the event of oil degradation, oil addition or change may alleviate certain performance problems. Refer to the vehicle manufacturer's recommended oil change frequency.

In the event of oil contamination or hydraulic system component failure, a complete teardown and inspection of the PRM will be required.

SECTION 5. REPAIR

HOW TO USE THIS MANUAL

The following procedures are presented in the order in which they must be performed to completely disassemble the unit. Each step is provided with an exploded view showing the parts involved. **The item reference numbers in each illustration are for disassembly/assembly instructions only.** See pages 24-25 for part names and descriptions. The disassembly section is followed by the assembly procedure. A complete exploded view and item list of the PRM® is provided at the end of this section.

GENERAL INSTRUCTIONS

Parts requiring replacement must be replaced from the appropriate kits identified in the Items Listing, found at the end of this manual. Use only original Hydro-Gear® replacement parts.

REQUIRED TOOLS

A list of tools required for the repair of the PRM motor is provided in Table 3 below.

TORQUE SPECIFICATIONS

Torque specifications for fasteners used on the PRM are provided in the assembly section of this manual.

TOOLS

Miscellaneous PRM Motor Service & Repair Manual Torque Wrench Impact Wrench 3/8" Drive Ratchet Scribe, Paint Pen, or Marker Seal Hook with a Magnet Flat Blade Screw Driver Hub Puller Adapter (included in seal kit)	Sockets 9/16" 1-5/16"
Pliers Internal Snap Ring External Snap Ring	Combination Wrenches 9/16"

PRM MOTOR REMOVAL

It is necessary to remove the PRM motor from the vehicle before performing the repair procedures represented in this section. Use the following procedure to prepare the unit for removal from the vehicle.

1. With the vehicle wheels on the ground, loosen the nut (55, Figure 48) Page 24, retaining the hub (56, Figure 48) Page 24. Use an air impact wrench and a 1-5/16" socket to loosen the nut.
 2. Lift the vehicle wheels from the ground and remove the nut completely.
 3. Remove the wheel from the hub.
 4. Using a wheel or gear puller and the hub puller adapter located in the seal kit, remove the hub from the shaft.
- NOTE: Anytime a hub nut and/or hub is removed, it must be discarded and replaced with a new hub nut and/or hub.**
5. Disconnect the brake arm linkage at the PRM motor.
 6. Disconnect the high pressure hoses and case drain hose at the PRM.
 7. Remove the PRM motor from the vehicle.

Table 3. Required Tools

SECTION 6. DISASSEMBLY

DISASSEMBLY

1. If the hub (56) has not been removed from the PRM®, remove the hex lock nut (55) with an impact wrench and discard. Remove the hub (56) and discard. If the axle shaft (34) turns during nut removal, manually apply the PRM brake actuating handle (36, Fig. 12) to prevent the axle from turning. Use a wheel or gear puller and the hub puller adapter, located in the seal kit, to remove the hub

NOTE: Anytime a hub nut and/or hub is removed, it must be discarded and replaced with a new hub nut and/or hub.

from the shaft.

2. Remove the woodruff key (71) from the axle shaft (34).

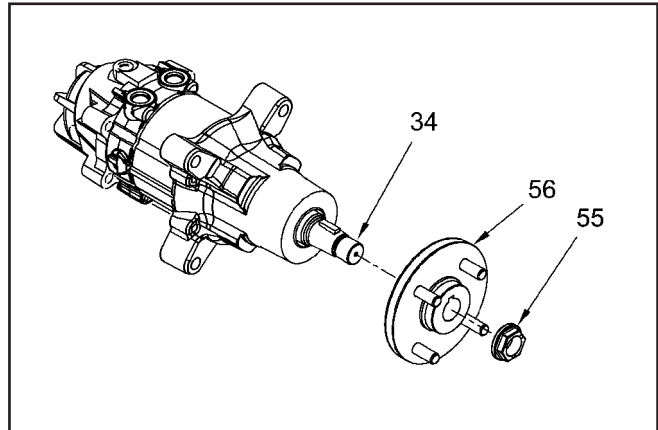

Figure 3

MA04K045

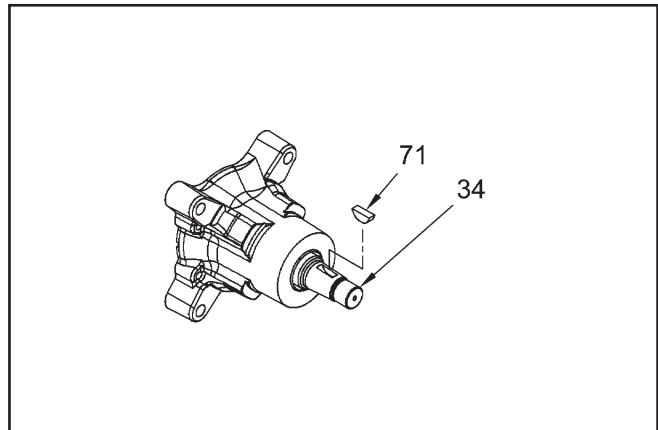

Figure 4

MA04K026

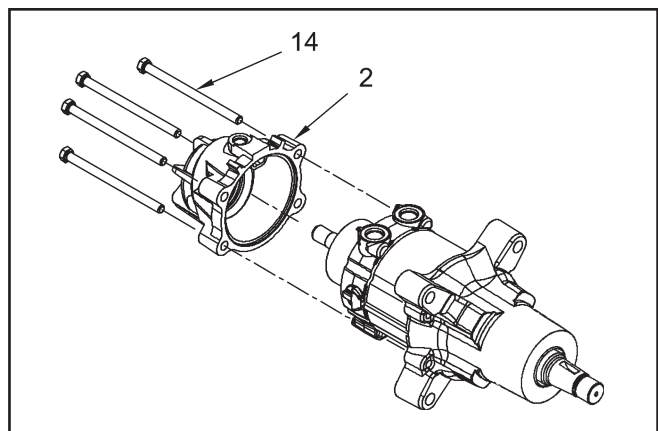

Figure 5

MA04N046

DISASSEMBLY (CONTINUED)

4. Remove the thrust bearing (7), from the motor housing (2).

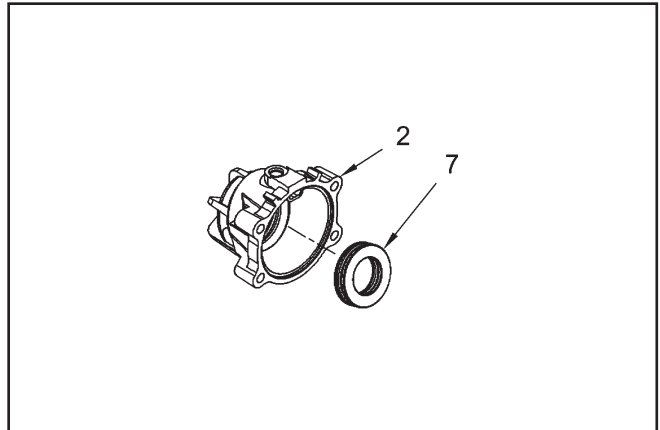

Figure 6

MA04M021

5. Inspect the thrust bearing (7), and motor housing needle bearing for damage or wear.

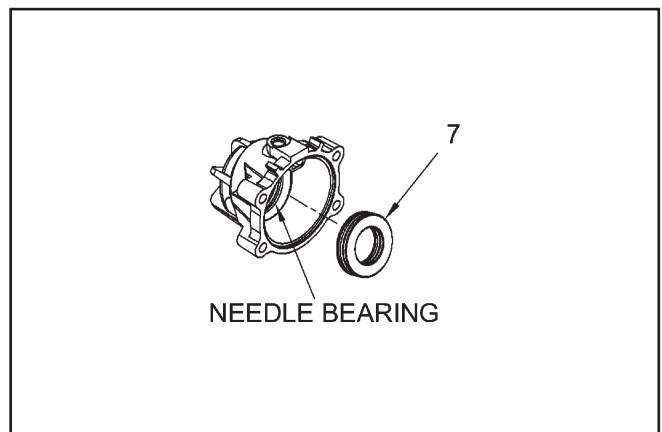

Figure 7

MA04K035

6. Remove the pistons, springs, and seats from the cylinder block (3) and inspect the components for damage or wear.

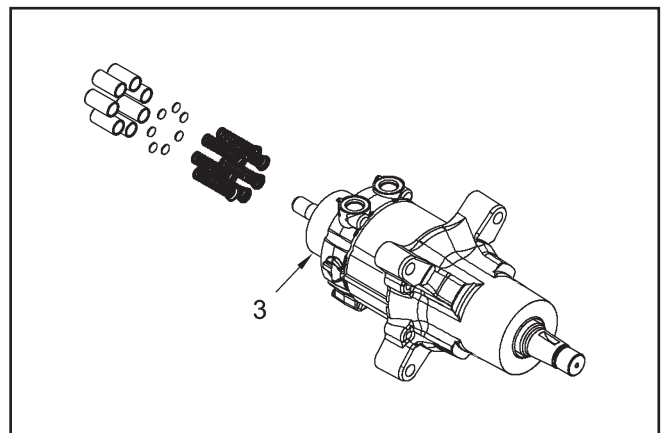

Figure 8

MA04M047

DISASSEMBLY (CONTINUED)

7. Compress the spring (12) and washer (11) to remove the motor shaft retaining ring (71), then remove the block compression spring (12) and washer (11) from the motor shaft (13).

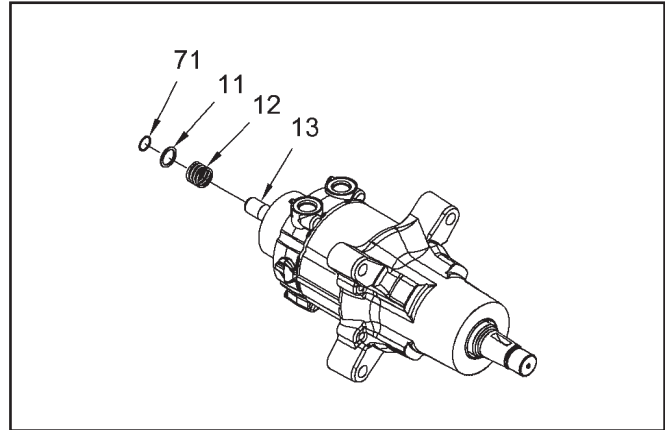

Figure 9

MA04K048

8. Remove the cylinder block (3) from the motor shaft (13). Inspect the cylinder block (3) for damage or wear.

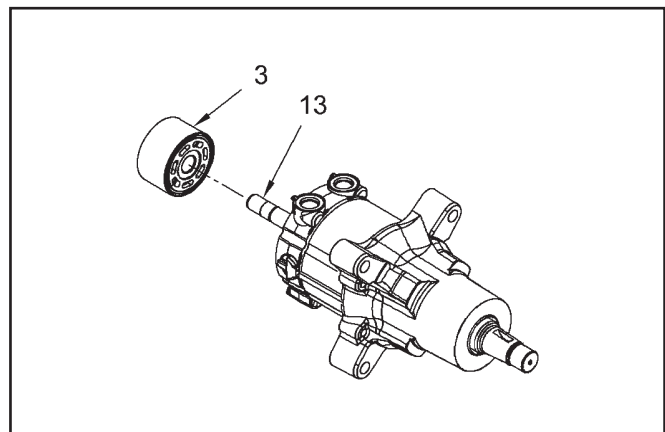

Figure 10

MA04K049

9. To ease reassembly, mark the port block (15), and ring gear (23) prior to disassembly. Also mark the brake actuating handle (36, Fig. 12) and brake cam (31, Fig. 14).

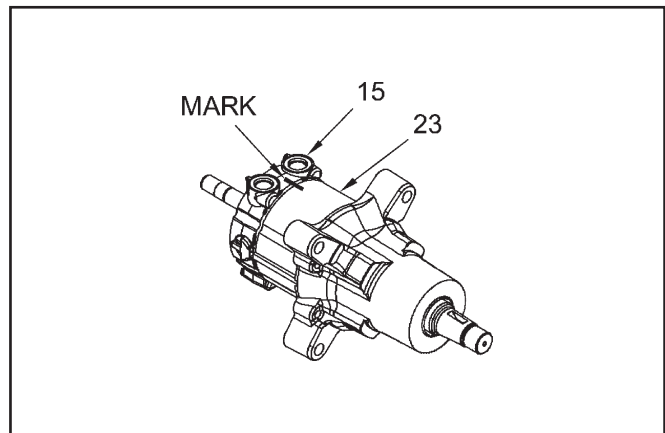

Figure 11

MA04K050

DISASSEMBLY (CONTINUED)

10. Remove the actuating handle retaining clip (38), and actuating handle (36).

11. Remove the port block (15) and brake puck

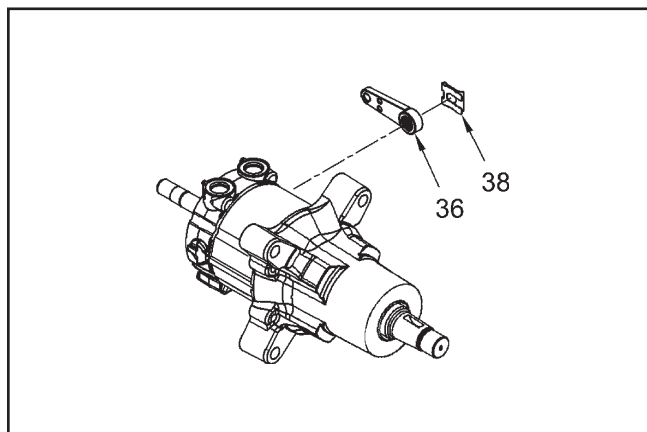

Figure 12

MA04K051

(42).

12. Remove the brake cam (31) from the port

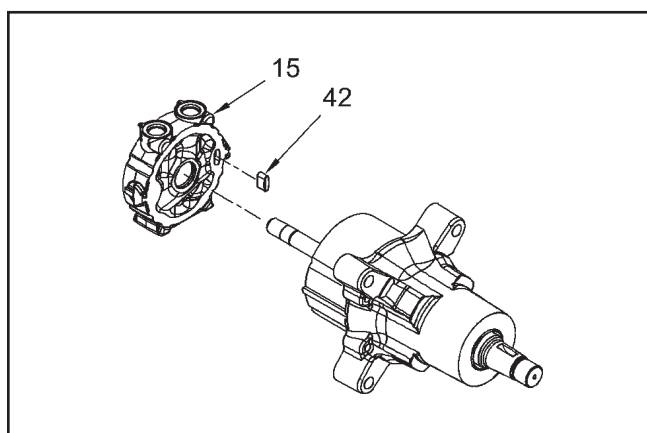

Figure 13

MA04K052

block (15).

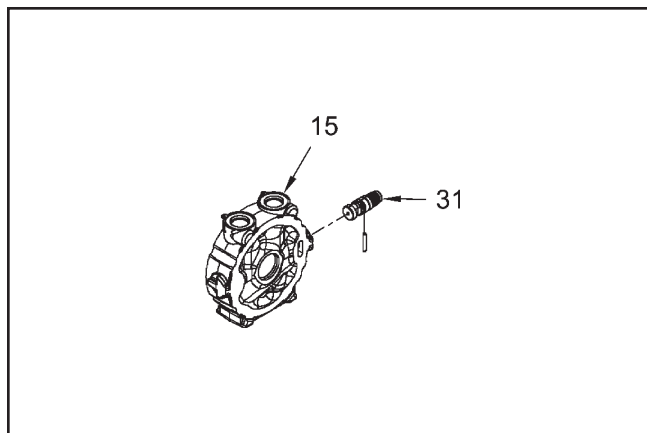

Figure 14

MA04K012

DISASSEMBLY (CONTINUED)

13. Remove the o-ring (71) from the port block (15).

14. Remove the o-ring (71) and stator spacer

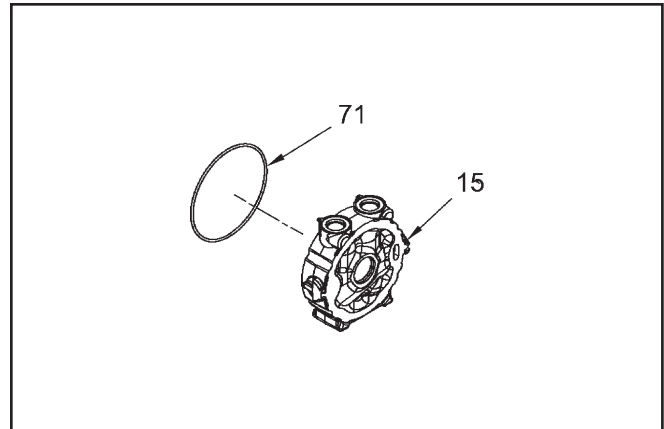

Figure 15

MA04K013

(29) from the ring gear (23).

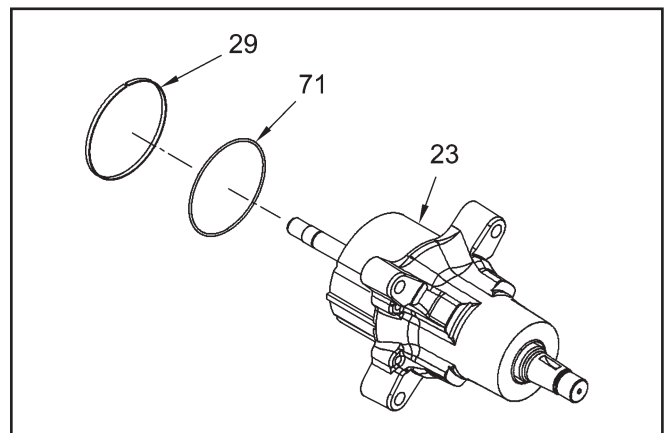

Figure 16

MA04K053

15. Remove the brake rotor (37), stator washer (25) and motor shaft (13). Inspect all for damage or wear.

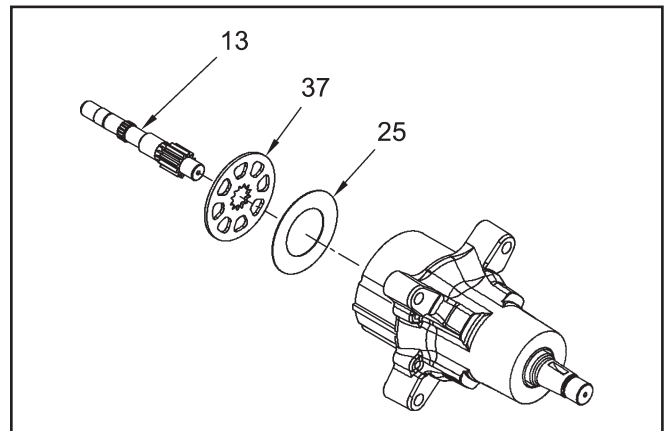

Figure 17

MA04N054

DISASSEMBLY (CONTINUED)

16. Remove the three 18T planetary gears (17), primary planetary carrier (19), three carrier pins (18), and washer (26) from the ring gear (23). Inspect the gears, carrier, pins and washer for wear or damage.

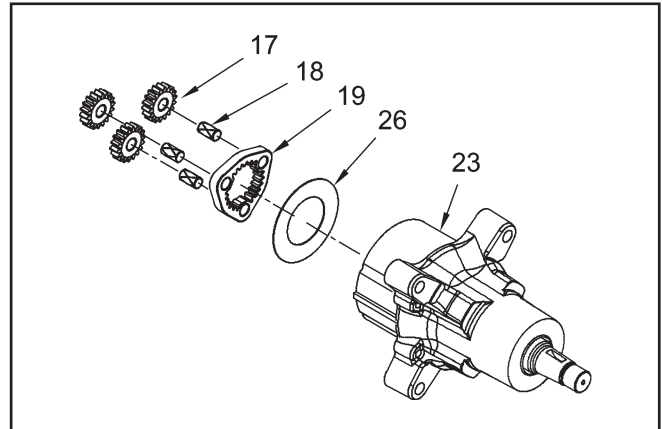

Figure 18

MA04K055

17. Remove the sun gear (20).

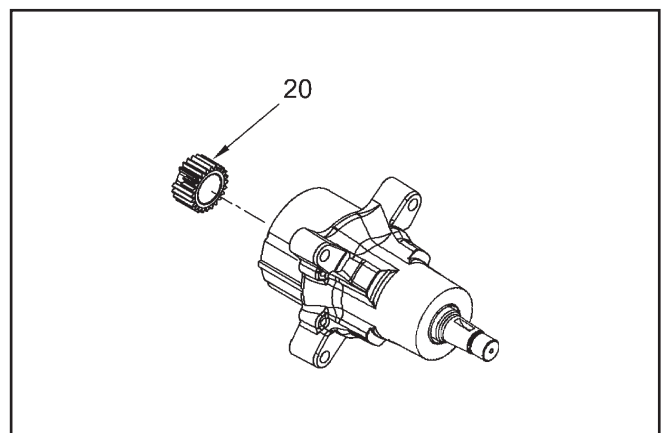

Figure 19

MA04K056

18. Remove the ring gear (23), six planetary gears (21), carrier pins (40), and o-ring (71). Inspect all components for wear or damage.

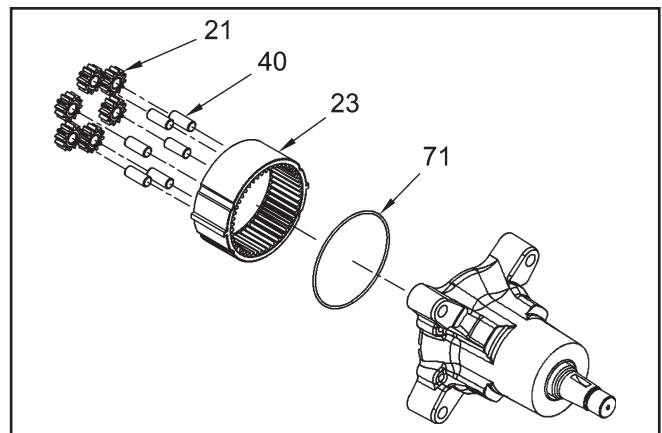

Figure 20

MA04K057

DISASSEMBLY (CONTINUED)

19. Remove the secondary planetary carrier (22), and washer (26) from the axle housing (1). Inspect for wear or damage.

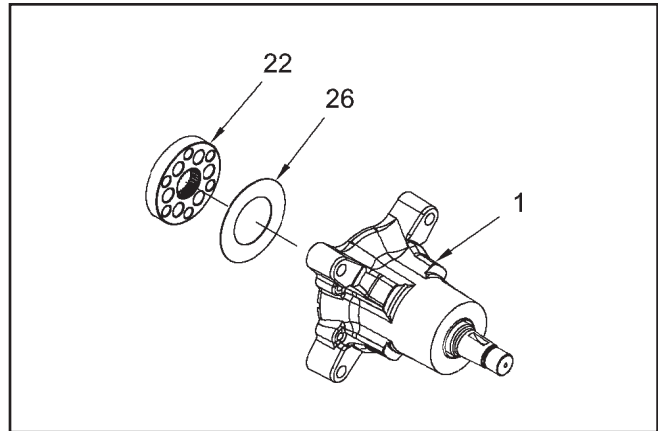

Figure 21

MA04K058

20. Remove the internal retaining ring (39), and axle shaft (34), with ball bearing from the axle housing (1).

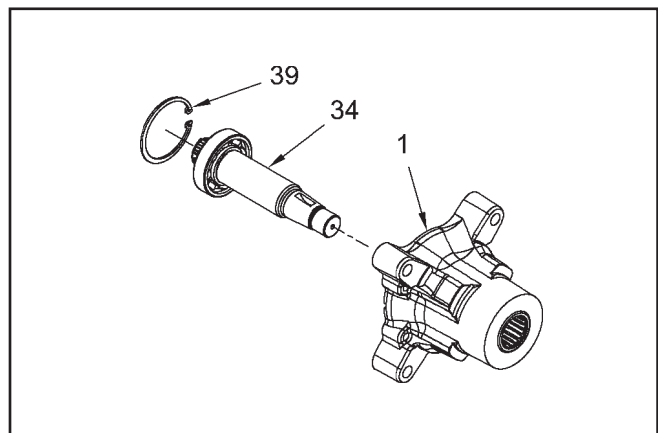

Figure 22

MA04K028

21. Remove the external retaining ring (35) and ball bearing (30) from the axle shaft (34). This is a press fit, so the bearing may be difficult to remove from the shaft. Inspect the bearing and shaft for wear or damage.

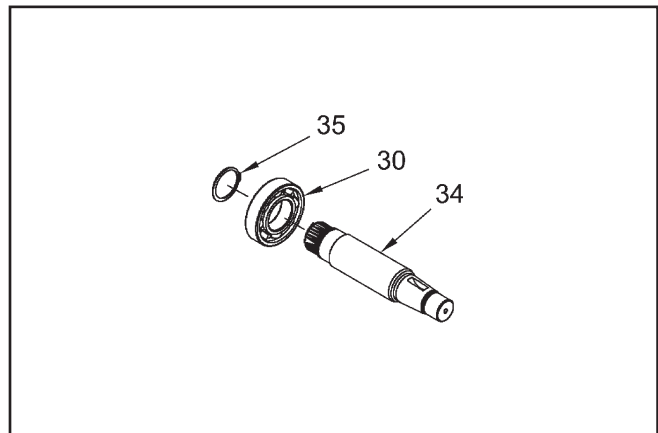

Figure 23

MA04K027

DISASSEMBLY (CONTINUED)

22. Inspect the axle housing needle bearing for damage or wear.

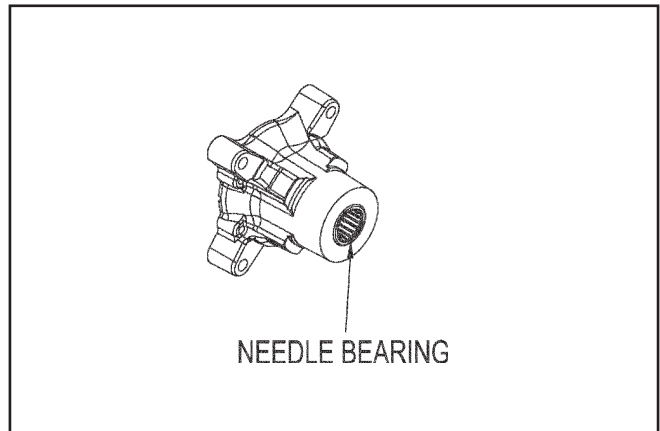

Figure 24

MA04K042

23. Remove the internal retaining ring (71) and lip seal (71) from the axle housing (1).

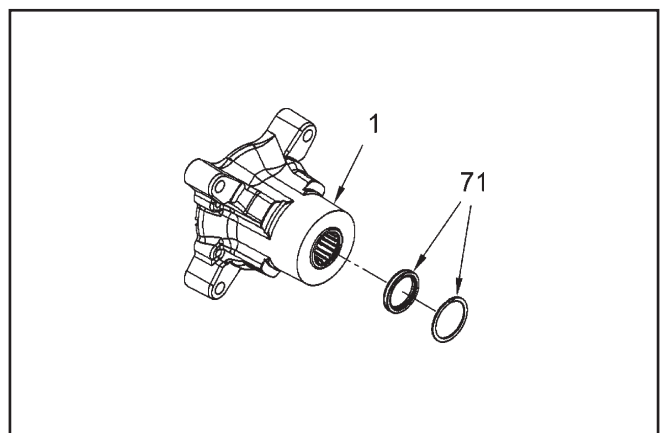

Figure 25

MA04K029

SECTION 7. ASSEMBLY

ASSEMBLY

1. Press the ball bearing (30) onto the axle shaft (34). Pressing force must be applied to the inner bearing race only. Secure the bearing with the retaining ring (35).

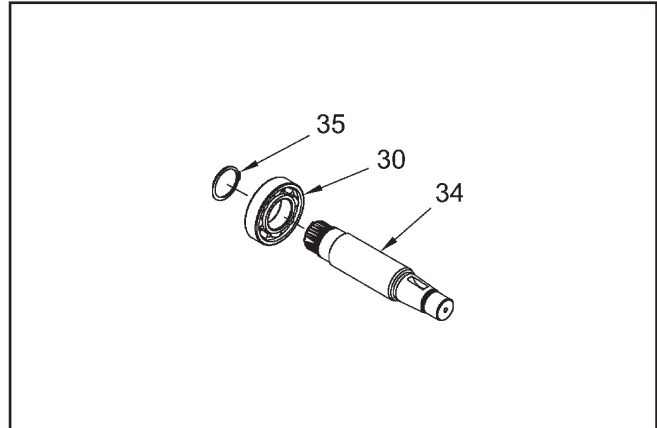

Figure 26

MA04K027

2. Install the lip seal (71) and internal retaining ring (71) into the axle housing.

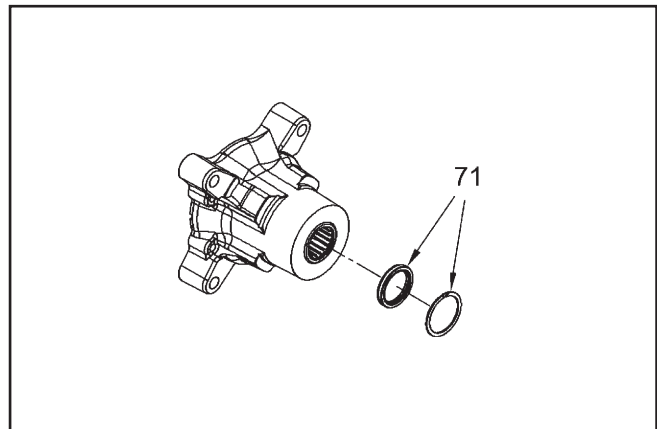

Figure 27

MA04K039

3. Install axle shaft (34) with ball bearing into housing (1) and secure with retaining ring (39).

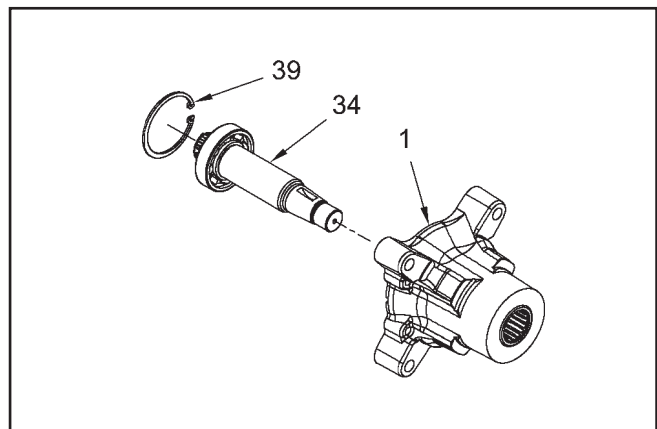

Figure 28

MA04N028

ASSEMBLY (CONTINUED)

- Note: Steps 4-19 will be best accomplished if the PRM motor is in a vertical position with the axle shaft facing down.

Install the washer (26) and secondary planetary carrier (22) into the axle housing (1). Make sure the recessed face of the secondary planetary carrier (22) faces away from the axle shaft.

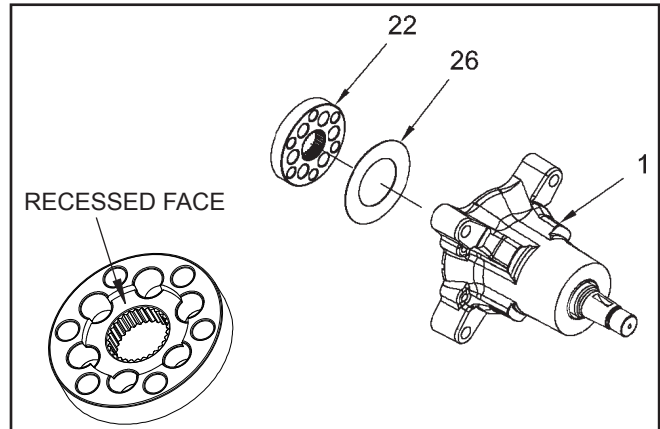

Figure 30

MA04K058

- Install the o-ring (71), ring gear (23), carrier pins (40) and six planetary gears (21). Make sure the mark that was placed on the ring gear in step 9 of the disassembly is oriented correctly.

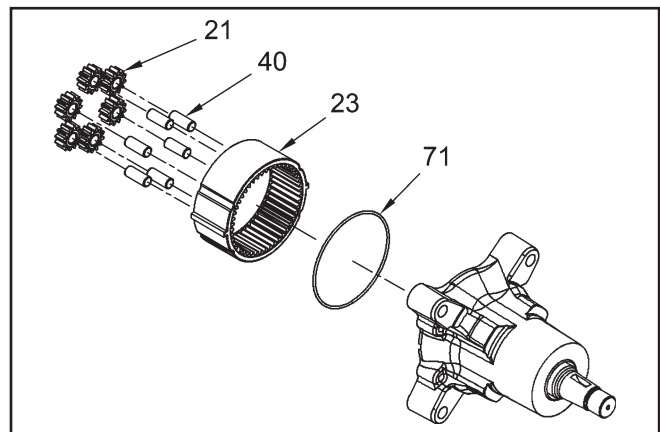

Figure 31

MA04K057

- Install the sun gear (20).

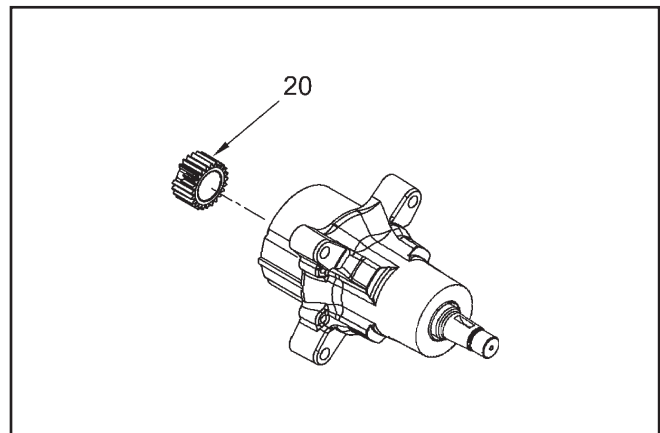

Figure 32

MA04K056

ASSEMBLY (CONTINUED)

7. Assemble the primary carrier (19), three carrier pins (18), and three planetary gears (17). Install the washer (26) and assembly into the ring gear (23).

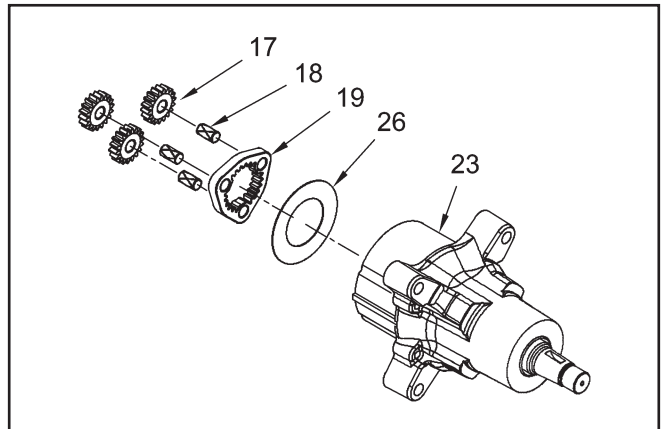

Figure 33

MA04K055

8. Install stator washer (25), brake rotor (37), and motor shaft (13) into the ring gear (23).

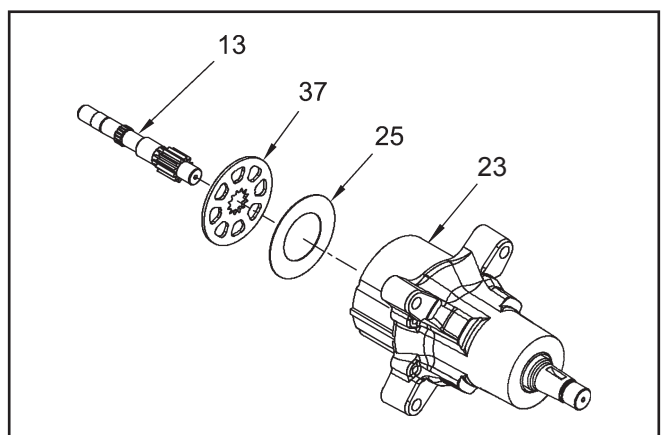

Figure 34

MA04N054

9. Install o-ring (71) and stator spacer (29) into the ring gear (23).

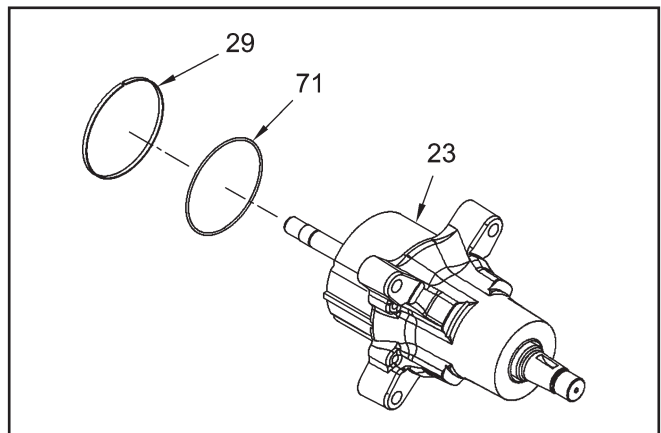

Figure 35

MA04K053

ASSEMBLY (CONTINUED)

10. Install o-ring (71), into the port block (15).

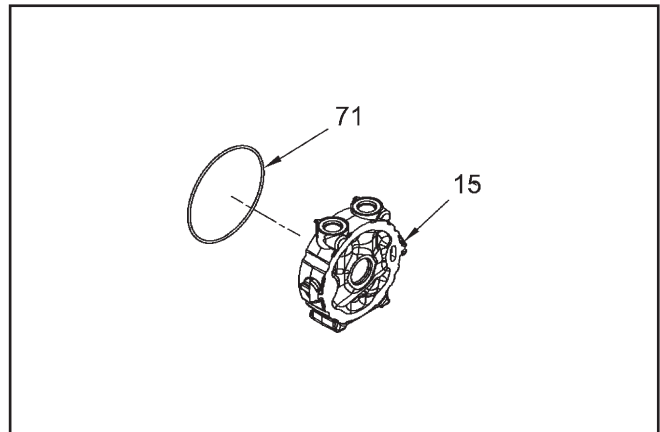

Figure 36

MA04K013

11. Install brake cam (31) into the port block (15).

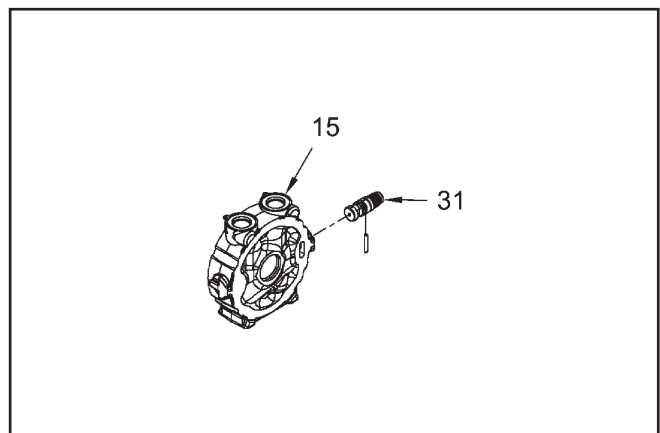

Figure 37

MA04K012

12. Install puck (42) into the port block (15), then install the port block onto the motor shaft (13). Note: When installing the port block assembly, pull on the cam (31, Fig. 37) to keep the puck (42) from falling out of the

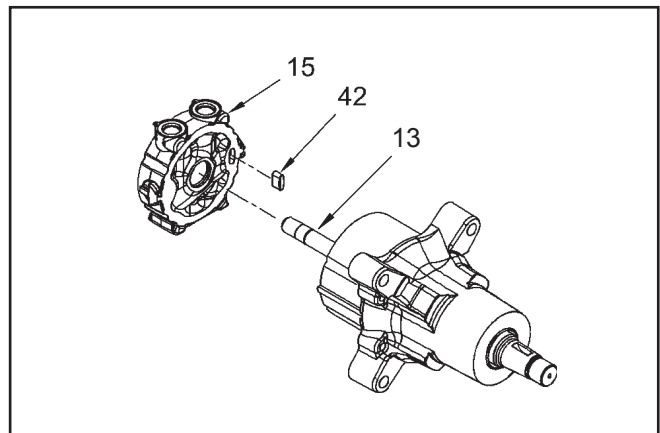

Figure 38

MA04K052

ASSEMBLY (CONTINUED)

13. Make sure the marks on the port block (15) and ring gear (23) are aligned.
14. Install actuating handle (36) onto the brake

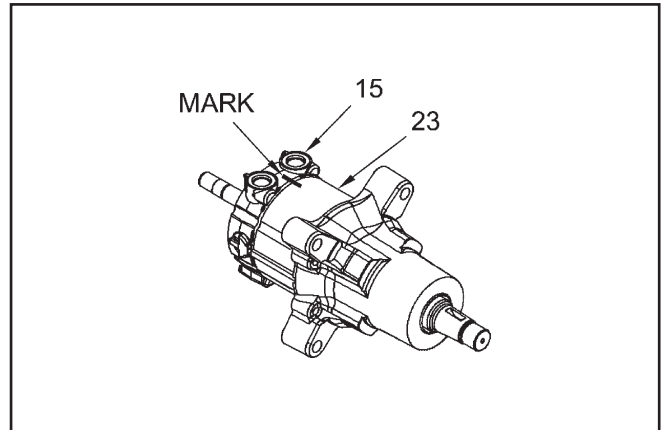

Figure 39

MA04K050

cam and secure with retaining clip (38). Make sure the marks on the actuating handle and brake cam are aligned.

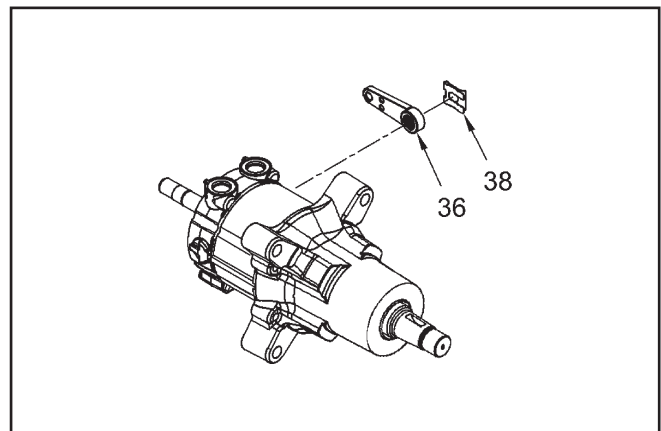

Figure 40

MA04K051

15. Install the cylinder block (3) onto the motor shaft (13).

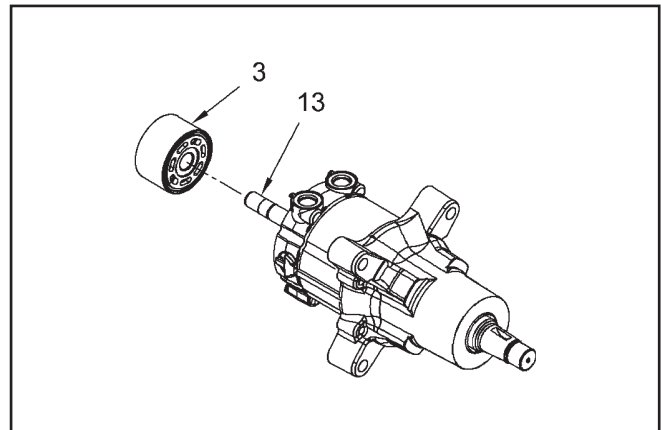

Figure 41

MA04K049

ASSEMBLY (CONTINUED)

16. Install compression spring (12), and washer (11) onto the motor shaft (13) then secure with the retaining ring (71).

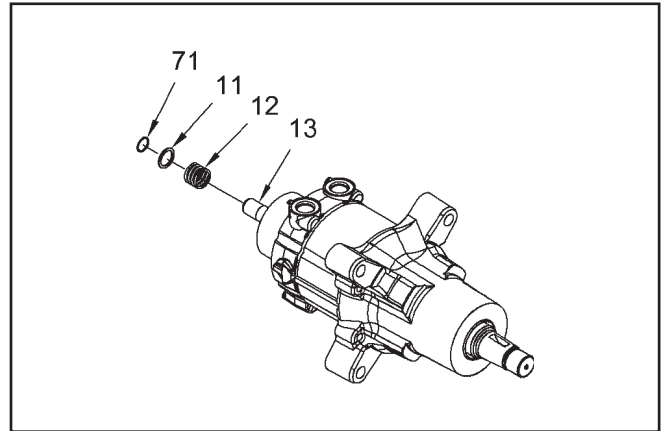

Figure 42

MA04K048

17. Install the springs, piston seats, and pistons into the cylinder block (3).

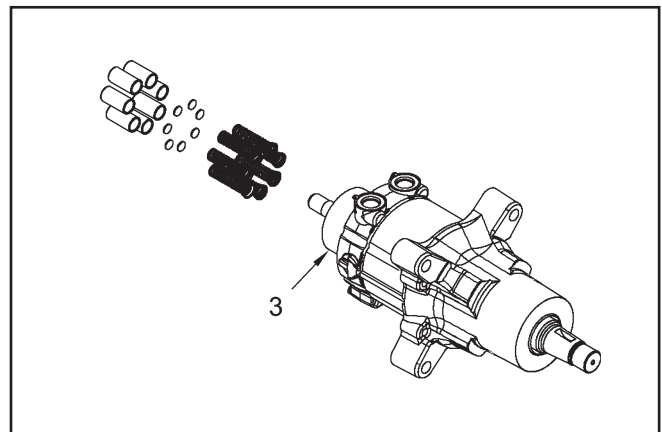

Figure 43

MA04M047

18. Place the thrust bearing (7) on the cylinder block pistons (3) and around the motor shaft (13). Be sure the thick race of the thrust bearing (7) is contacting the pistons.

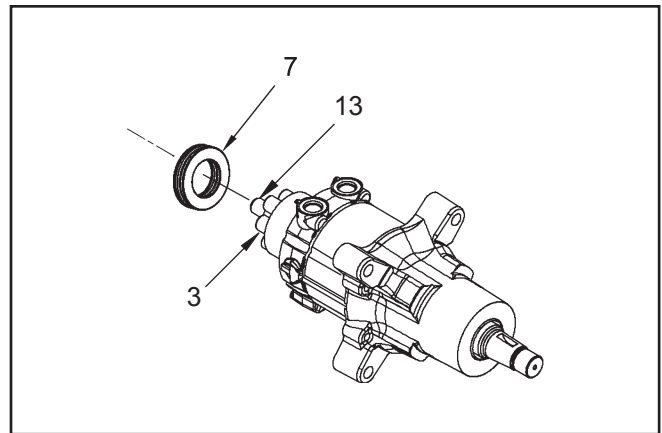

Figure 44

MA04M061

ASSEMBLY (CONTINUED)

19. With the PRM® still in the vertical position, use four housing screws (14) to secure the motor housing (2) to the axle housing (1). Tighten the four housing screws in a criss-cross pattern and evenly to 39-47 ft-lbs (53-64 Nm).

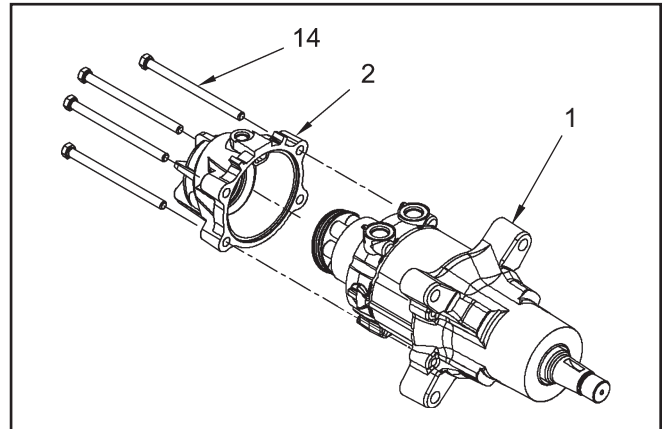

Figure 45

MA04M063

20. Install the woodruff key (71) into the axle shaft (34).

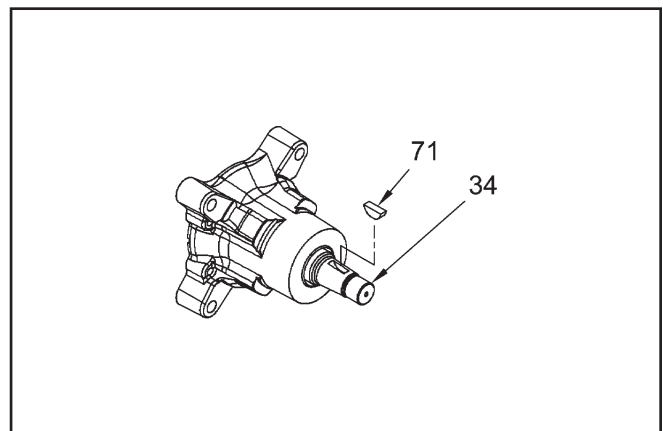

Figure 46

MA04K026

21. Install hub (56) onto the axle shaft (34) and secure with top lock nut (55). Torque the top lock nut or castle nut according to the chart below. Manually apply the brake actuating handle to prevent the axle shaft from turning when tightening the hex lock nut. Final nut tightening can also be accomplished after the PRM and wheel have been installed on the vehicle and the vehicle is setting on the ground.

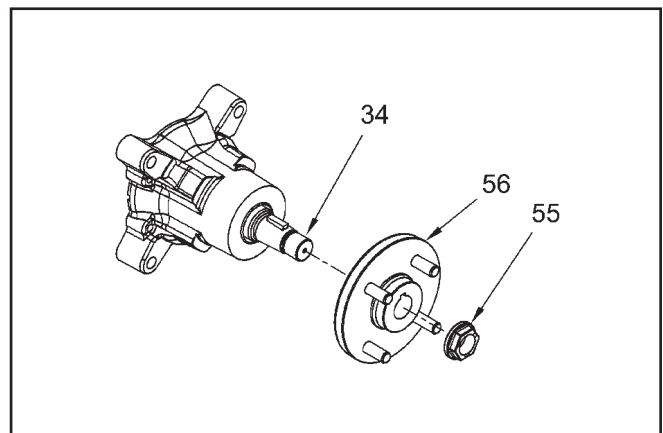

Figure 47

MA04K025

Top Lock Nut (Item 55)- SILVER hub configuration:

Prior to serial number 0256Xxxxxx: 210 - 250 ft.lbs.

Top Lock Nut (Item 55)- BLACK hub configuration:

Prior to serial number 0256Xxxxxx: 305 - 345 ft.lbs

Castle Nut (Item 55) - BLACK or SILVER hub configuration:

On or after serial number 0256Xxxxxx: 275 - 345 ft.lbs

SECTION 8. PARTS LIST

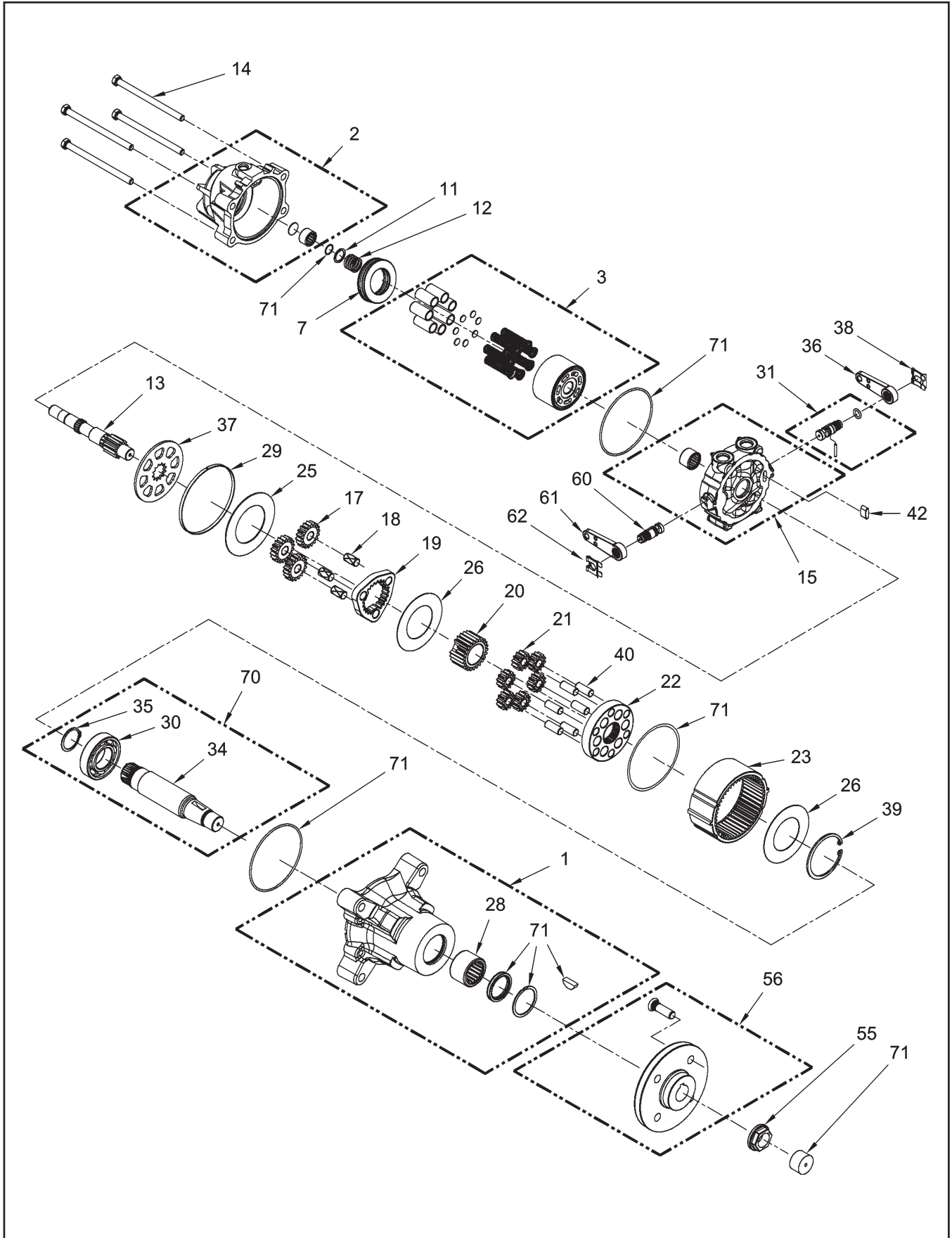

Figure 48

MA04K030

ITEMS LIST

Part numbers are not provided in this manual.

NO.	DESCRIPTION	NO.	DESCRIPTION
1	Axle Housing Kit	29	Stator Spacer
2	Motor Housing Kit	30	Ball Bearing
3	Motor Block Kit	31	Brake Cam Kit
7	Thrust Bearing	34	Shaft, Axle
11	Washer	35	Retaining Ring - External
12	Spring	36	Handle, Actuating
13	Shaft, Motor	37	Brake Rotor
14	Screw, HFHCS 3/8-16 x 5.5	38	Retaining Clip
15	Port Block Kit	39	Retaining Ring - Internal
17	18T Planet Gear	40	Carrier Pin
18	Carrier Pin	42	Brake Puck
19	Primary Planetary Carrier	55	Nut, Hex Lock
20	24T Sun Gear	56	Hub Kit
21	12T Planet Gear	60	Brake Cam Kit
22	Secondary Planetary Carrier	61	Handle, Actuating
23	48T Ring Gear	62	Retaining Clip
25	Stator Washer	70	Axle Shaft Kit
26	Washer	71	Seal Kit
28	Needle Bearing		

SECTION 9. GLOSSARY OF TERMS

Axial Piston: Type of design for hydraulic motors and pumps in which the pistons are arranged parallel with the spindle (input or output shaft).

Bypass Valve: A valve whose primary function is to open a path for the fluid to bypass the motor or pump. Also referred to occasionally as the freewheel valve or dump valve.

Case Drain Line (Return Line): A line returning fluid from the component housing to the reservoir.

Cavitation: A concentrated gaseous condition within the fluid causing the rapid implosion of a gaseous bubble.

Center Section: A device which acts as the valve body and manifold of the transmission.

Charge Pump: A device which supplies replenishing fluid to the fluid power system (closed loop).

Charge Pressure: The pressure at which replenishing fluid is forced into a fluid power system.

Charge Relief Valve: A pressure control valve whose primary function is to limit pressure in the charge circuit.

Check Valve: A valve whose primary function is to restrict flow in one direction.

Closed Loop: A sealed and uninterrupted circulating path for fluid flow from the pump to the motor and back.

Decay Rate: The ratio of pressure decay over time.

End Cap: See "Center Section"

Entrained Air: A mechanical mixture of air bubbles having a tendency to separate from the liquid phase.

Gerotor: A positive displacement pump frequently used as a charge pump.

Hydraulic Motor: A device which converts hydraulic fluid power into mechanical force and motion by transfer of flow under pressure.

Hydraulic Pump: A device which converts mechanical force and motion into hydraulic fluid power by producing flow.

Hydrostatic Pump: See "Hydraulic Pump"

Hydrostatic Transaxle: A multicomponent assembly including a gear case and a hydrostatic transmission.

Hydrostatic Transmission: The combination of a hydraulic pump and motor in one housing to form a device for the control and transference of power.

Inlet Line: A supply line to the pump.

Integrated Hydrostatic Transaxle (IHT): The combination of a hydrostatic transmission and gear case in one housing to form a complete transaxle.

Manifold: A conductor which provides multiple connection ports.

Neutral: Typically described as a condition in which fluid flow and system pressure is below that which is required to turn the output shaft of the motor.

Pressure Decay: A falling pressure.

Priming: The filling of the charge circuit and closed loop of the fluid power system during start up, frequently achieved by pressurizing the fluid in the inlet line.

Purging: The act of replacing air with fluid in a fluid power system by forcing fluid into all of the components and allowing the air a path of escape.

Rated Flow: The maximum flow that the power supply system is capable of maintaining at a specific operating pressure.

Scoring: Scratches in the direction of motion of mechanical parts caused by abrasive contaminants.

Swash Plate: A mechanical device used to control the displacement of the pump pistons in a fluid power system.

System Charge Check Valve: A valve controlling the replenishing flow of fluid from a charge circuit to the closed loop in a fluid power system.

System Pressure: The pressure which overcomes the total resistance in a system, including all losses.

Valve: A device which controls fluid flow direction, pressure, or flow rate.

Variable Displacement Pump: A pump in which the displacement per cycle can be varied.

Volumetric Displacement: The volume for one revolution.

NOTES

NOTES



© 2010 HYDRO-GEAR
Printed in U.S.A.
BLN-52179_P6

